



1st Floor, R&D Building, No.3 Guangpuxi Avenue, Science City,
Guangzhou China
Tel : +8620-89269660/89269669/89269662

1Room 2120, Hongfa center Building, No.1004, Xinhua Road,
Bao'an District, Shenzhen,China
Tel : +86755-27802026/27802025

No.306 E-Building, Greenland Central Square, No.48 Science
Avenue, Huangpu District, Guangzhou China
Tel : +8620-85559392

PATENT DESIGN

PROVIDE YOU THE BEST SOLAR SOLUTION

ANERN INDUSTRY



SOLAR STREET LIGHT

ANERN PATENT DESIGN
EXCLUSIVE MANUFACTURE

ADVANTAGES



OEM/ODM SERVICE

Solar Energy Pioneer

Offer OEM/ODM service and one-stop solution as per your specific requirements, customize the solar led lighting solutions in the practical application.



PROFESSIONAL PRODUCTION

Solar Energy Pioneer

Standardized production line and advanced production equipment, strictly control the manufacturing process and quality inspection to provide customers with qualified products.



SERVE CLIENTS WORLDWIDE

Solar Energy Pioneer

Dedicated in bringing clean energy to each country, Anern have successfully completed hundreds of mega government projects in more than 180 countries in the past 12 years.



COMPANY PROFILE

As a leader in led lighting and solar applications, Anern insists on integrating the advanced technology and professional design into every solution and blending the best service with the highest quality products, aiming at each client's satisfaction. So far we have provided service to over 180 countries and areas globally, which has won clients' uniform praise.

In the past 12 years, Anern has developed series of products relating to solar power and led lighting based on market demand, and owns over 20 patents for self-developed products.





WE HAVE A NEW WAY
**TO CHANGE THE
 DIRECTION OF LIGHT**



-25°C to 65°C



4-5 Nights



Waterproof IP65

AN-SLA SOLAR STREET LIGHT

Technical Indexes

Power	30W	50W	60W	80W	100W	120W
LED	3030 Bridgelux High Efficiency LED Chip					
Luminous Flux	5300lm	8200lm	10000lm	13000lm	16700lm	20000lm
LiFePO4 Battery	12.8V/24AH	12.8V/36AH	12.8V/42AH	12.8V/57AH	12.8V/63AH	12.8V/72AH
Mono Solar Panel	18V50W	18V70W	18V80W	18V100W	18V130W	18V140W
Install Height	4~6 m	5~7 m	5~8 m	6~9 m	7~10 m	7~10 m
Material	Aluminium alloy + PMMA					
Solar charging time	6-8 hours by bright sunlight					

Description

- Adjustable angle module **NEW**
- 140° wide lighting angle
- Easy to install and Auto on/off/sensor
- Night sensor + Microwave motion sensor+Remote Control

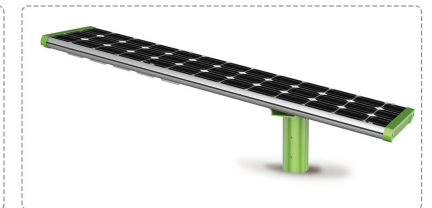
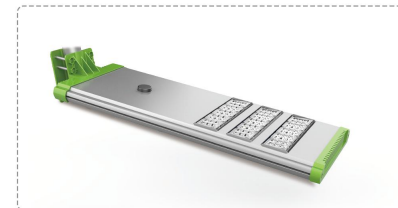
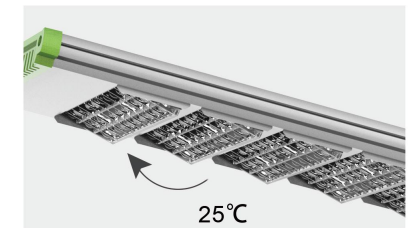

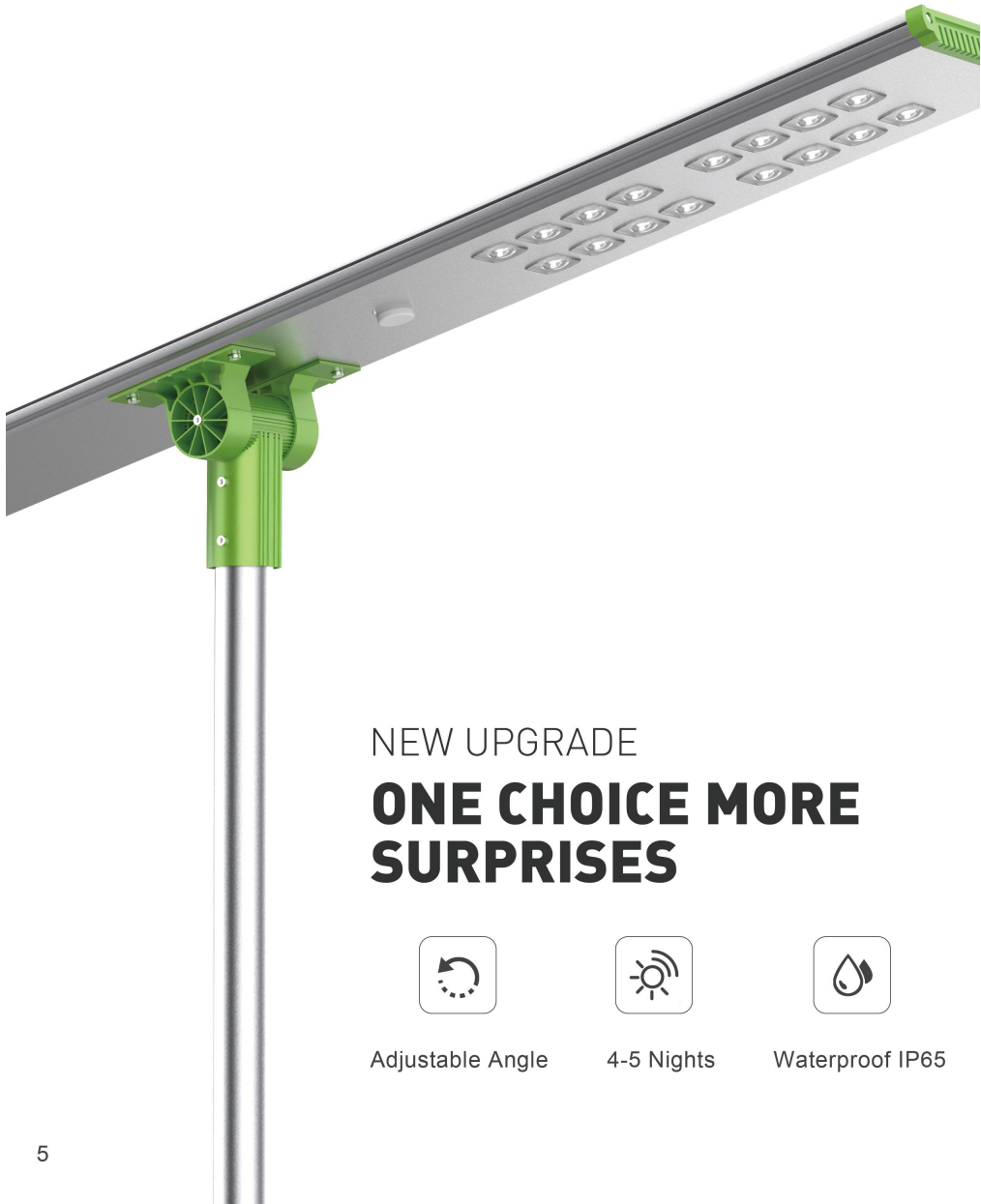

NEW UPGRADE
ONE CHOICE MORE SURPRISES



Adjustable Angle



4-5 Nights



Waterproof IP65

AN-SLA SOLAR STREET LIGHT



Various LED modules are available

01

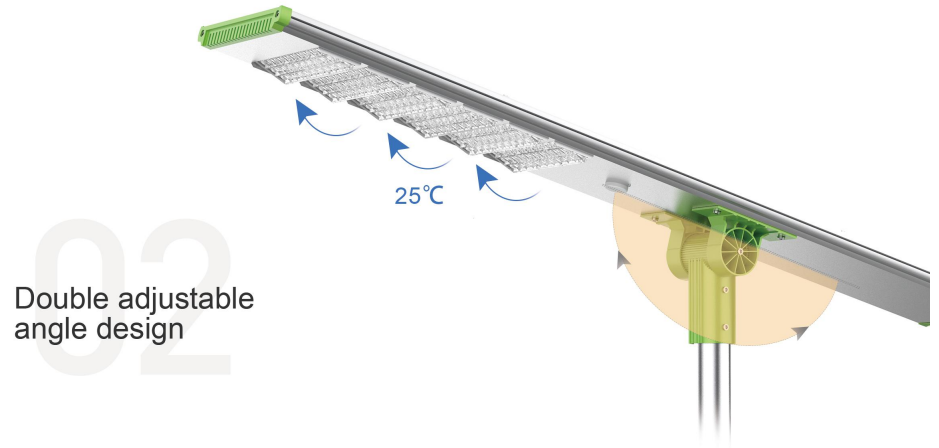

Double adjustable angle design



Can be equipped with a CCTV

03

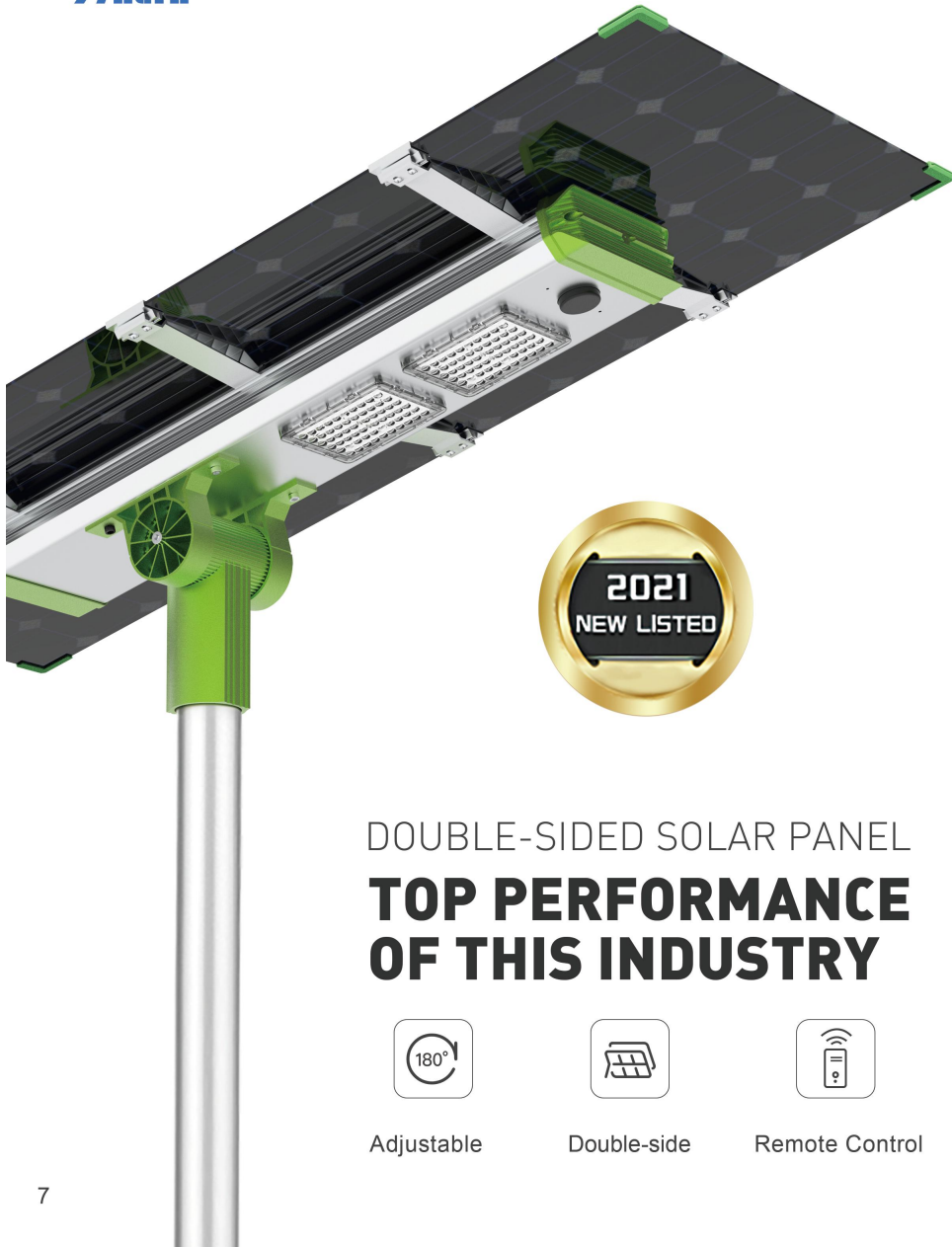

DOUBLE-SIDED SOLAR PANEL
**TOP PERFORMANCE
OF THIS INDUSTRY**



Adjustable



Double-side



Remote Control

AN-SL-X SOLAR STREET LIGHT

Description

- Independent design of **double-side solar panel** NEW
- 180° adjustable angle bracket
- Up to 200W, specially design for engineering
- Night sensor + Microwave motion sensor
+Remote Control
- PIR sensor, more than 8m sensing distance

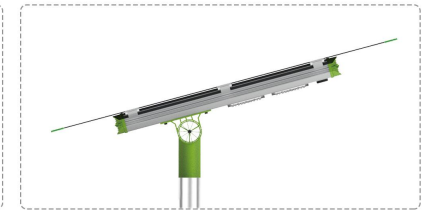
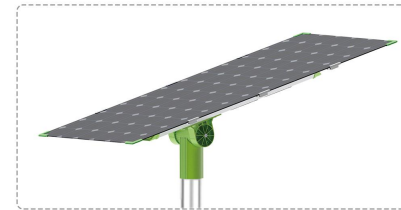
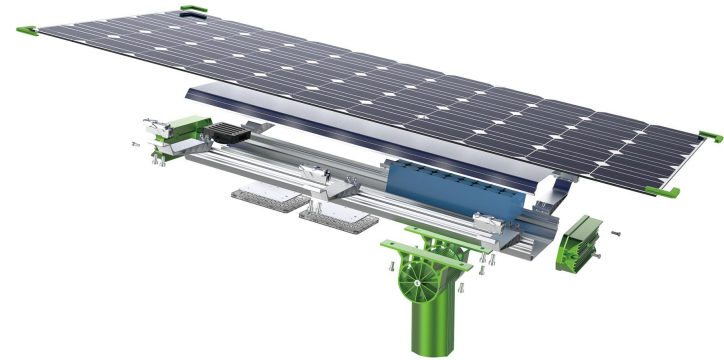

AN-SL-X SPECIFICATIONS

Technical Indexes

Power	60W	80W	100W	120W	150W	200W
LED	80pcs 3030	80pcs 3030	120pcs 3030	120pcs 3030	120pcs 5050	120pcs 5050
Luminous Flux	10000lm	13000lm	16700lm	20000lm	25000lm	33000lm
LiFePO4 Battery	12.8V/42AH	12.8V/57AH	12.8V/63AH	12.8V/72AH	12.8V/90AH	25.6V/66AH
Mono Solar Panel	18V120W	18V140W	18V160W	18V180W	18V200W	36V260W
Install Height	5-8m	6-9m	7-10m	7-10m	8-12m	8-12m
Material	Aluminium alloy + PMMA					
Solar Charging Time	6-8 hours by bright sunlight					
Lighting Time In Rainy Day	10 days					
Lighting Mode	12hrs motion sensor control (Bright lighting 30secs when people move through the light)+Remote Controller					
PIR	120°, >8m					
IP / IK Class	IP 65 / IK 10					
Work Temperature	-25°C to 65°C					

AN-SL-X PRODUCT ADVANTAGE

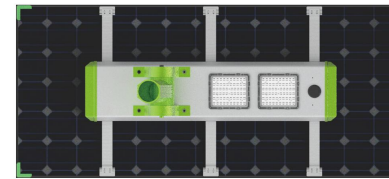

01 DOUBLE-SIDED SOLAR PANEL

Maximumly improved the power generation by 30%-50%

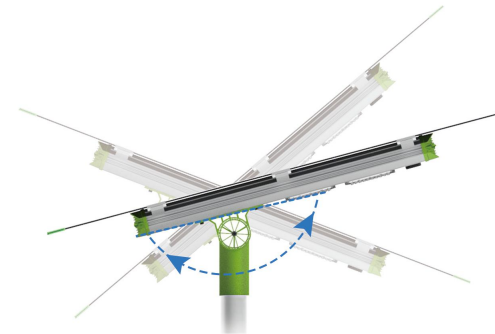

02 ADJUSTABLE ANGLE BRACKET

180° arbitrary adjustment

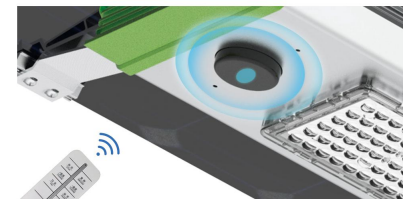

03 REMOTE CONTROLER

4 lighting modes for optional

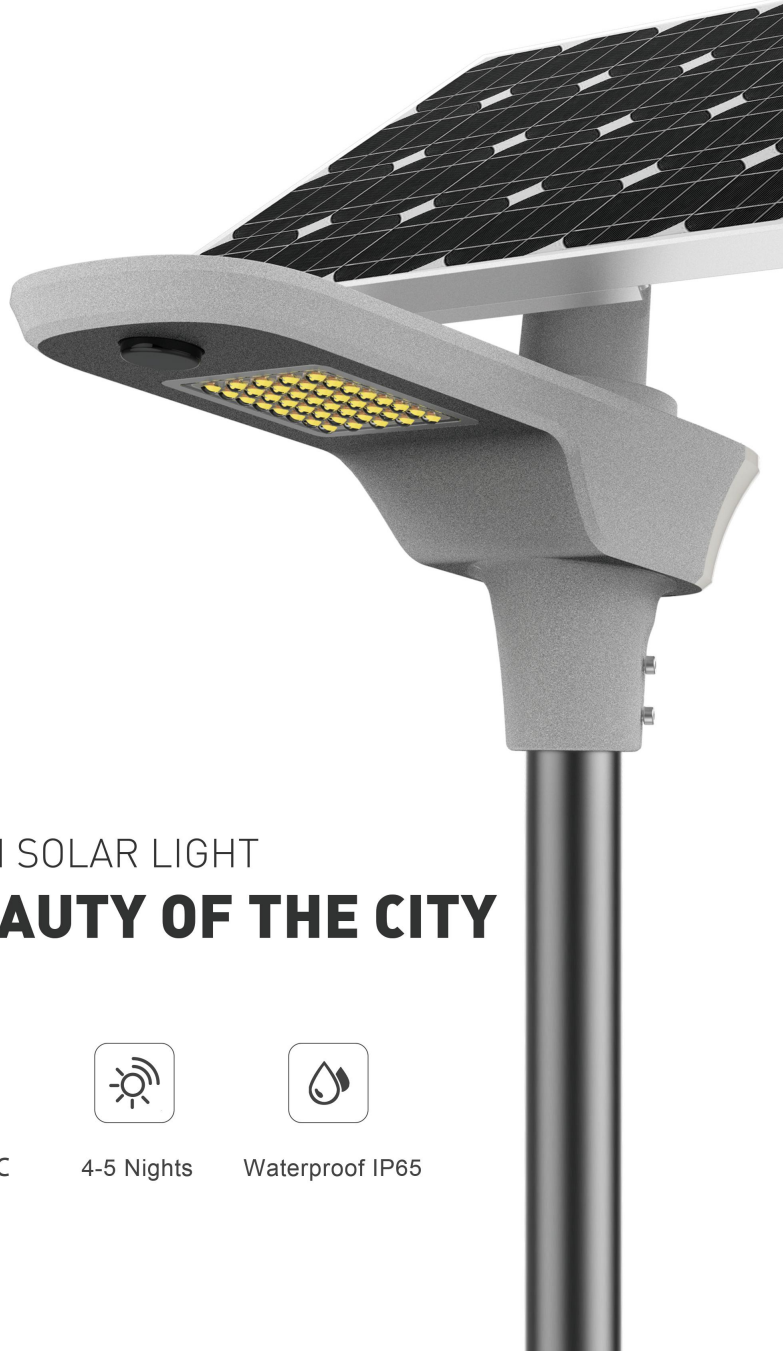

ANERN SOLAR LIGHT
A BEAUTY OF THE CITY



-25°C to 65°C



4-5 Nights



Waterproof IP65

AN-SL SOLAR STREET LIGHT

Technical Indexes

Power	15W	25W	30W	40W	60W	80W
LED	3030 Bridgelux High Efficiency LED Chip					
Luminous Flux	3000lm	5000lm	6000lm	8000lm	10000lm	12000lm
LiFePO4 Battery	12V/18AH	12V/28AH	12V/36AH	12V/42AH	12V/75AH	12V/86AH
Mono Solar Panel	18V40W	18V65W	18V80W	18V100W	18V170W	18V200W
Install Height	3~4 m	5~6 m	6~7 m	6~7 m	8~9 m	8~9 m
Material	Aluminium alloy + PMMA					
Solar charging time	6-8 hours by bright sunlight					

Description

- Adjustable angle solar panel HOT
- 140° wide lighting angle
- Night sensor + Microwave motion sensor + Remote Control
- Fast battery replacement, no need of taking apart whole luminaire





PRESENT HIGH QUALITY
**INTEGRAL DIE-CASTING
 SOLAR STREET LIGHT**



LG 3030 Chips



5 Nights



Waterproof IP65

AN-ISSL-C SOLAR STREET LIGHT

Technical Indexes

Power	60W	80W	100W
LED	200/144pcs LG chips3030	300/216pcs LG chips3030	500/288pcs LG chips3030
Luminous Efficiency	150lm/w		
LiFePo4 Battery	128WH	160WH	192WH
Mono Solar Panel	30W	40W	50W
Install Height	4~6 m	6~7 m	7~8 m
Material	Die-casting Aluminium		
Solar Charging Time	5-6 hours by bright sunlight		

Description

- Integral die-cast housing, high mechanical strength
- LG 3030 LED chips, maximum brightness up to 150lm/W, 30%
- Snap-type battery box design
- Adjustable angle lamp arm NEW





ADJUSTABLE LED MODEL
ALL IN TWO SOLAR STREET LIGHT



-25°C to 65°C



5-7 Nights



Waterproof IP65

AN-SSL-I SOLAR STREET LIGHT

Technical Indexes

Power	30W	40W	50W	60W	80W	100W	120W
LED	96pcs	96pcs	144pcs	144pcs	192pcs	240pcs	240pcs
Luminous Efficiency	170lm/w						
LiFePo4 Battery	12.8V 24AH	12.8V 28AH	12.8V 36AH	12.8V 42AH	12.8V 57AH	12.8V 63AH	12.8V 72AH
Mono Solar Panel	40W	50W	65W	80W	100W	150W	200W
Install Height	4~6 m	5~7 m	6~8 m	7~9 m	8~10 m	9~12 m	10~12 m
Material	Aluminium + PMMA						
Solar Charging Time	6-8 hours by bright sunlight						

Description

- Wiring only takes one step, easy to install and maintain
- Adjustable angle LED module, suitable for different roads NEW
- Big battery box, build-in new LifePo4 battery
- Adjust brightness via remote control

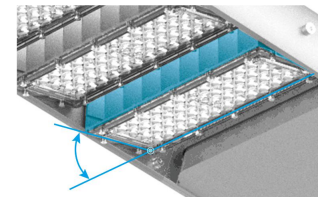



2021 THE FIRST CHOICE FOR
ENGINEERING LIGHTING

DIE-CAST ALUMINUM ALL IN ONE SOLAR STREET LIGHT



Big Battery Box



5-7 Nights



Waterproof IP65

AN-SLZ SOLAR STREET LIGHT

Technical Indexes

Power	40W	50W	60W	80W	100W	120W
LED	3030 Bridgelux High Efficiency LED Chip					
Luminous Flux	6600lm	8200lm	10000lm	13400lm	16700lm	20000lm
LiFePo4 Battery	12.8V28AH	12.8V36AH	12.8V42AH	12.8V57AH	12.8V63AH	12.8V72AH
Mono Solar Panel	65W	70W	80W	100W	130W	140W
Install Height	4~6 m	5~7 m	5~8 m	6~9 m	7~10 m	9~12 m
Material	Aluminium + PMMA					
Solar Charging Time	6-8 hours by bright sunlight					

Description

- New customized LED module, brightness increased by 20%. **NEW**
- Die-cast aluminum housing design, anti-typhoon level up to 16.
- Big battery box design, super long lighting time.
- Remote control can change the lighting mode.

